

## SCX STRAW CRIMPER

Spring-loaded independent disc suspension will smooth out the bumps, grinds, twists and turns of any ground condition.



*Each spring-loaded coulters disc can pivot and rise up and down independently from each other to maintain firm engagement with the ground for a smooth, uniform installation.*





## Features and Specifications

Burchland's ALL NEW SCX Straw Crimper lets you say good-bye to poorly secured, uneven straw installation due to rocks, roots, stumps—and even sidewalks. Why? Because each SCX disc can pivot left and right and up and down—independently from each other. No other crimper offers this time saving, quality installation feature. When a conventional single-shaft crimper hits a rock, the whole shaft lifts up and can totally disengage the soil. Not so with the SCX. *When an SCX disc hits an object, it floats over or pivots around it*, while the other discs remain firmly engaged with the soil. The disc pivoting action also allows for smoother, tighter turns for faster installation. These features along with the SCX's sturdy construction and ease of operation let you confidently and uniformly crimp straw—that will stay crimped—to keep soil in place and undisturbed... even in high winds or heavy rainfall. Give us a call today! 641-498-2063



**Heavy gauge tubular frame stands up to the toughest conditions.**



**Category-1 and -2 3-point hitch models to 6, 8 and 10 foot widths. Trailer versions are available to a maximum width of 16 feet. All sizes come with supplemental weight bins.**



**Pivoting coupler assembly with heavy-duty, heat-treated, spring-loaded notched discs, prevents rocks from wedging between discs.**

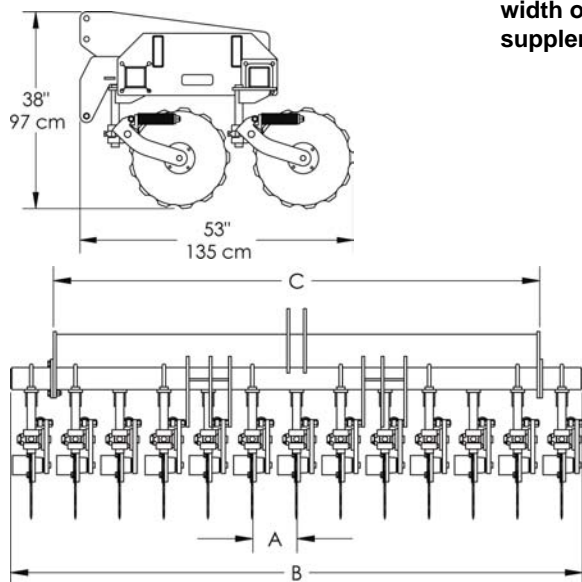

**8" disc spacing is standard, other disc spacings are available.**



**Rock Guards prevent damage to bearing hubcaps.**

### SCX Specifications

Crimper Width	"A" Disc Spacing	"B" Overall Width	"C" Shipping Width	Empty Weight	Number of Discs
6' (183 cm)	6" (15.2 cm)	76.5" (195 cm)	76.5" (195 cm)	1580 lbs. (717 kg)	13
6' (183 cm)	8" (20.3 cm)	76.5" (195 cm)	76.5" (195 cm)	1365 lbs. (620 kg)	10
8' (244 cm)	6" (15.2 cm)	103.5" (263 cm)	88" (224 cm)	1950 lbs. (885 kg)	17
8' (244 cm)	8" (20.3 cm)	103.5" (263 cm)	88" (224 cm)	1664 lbs. (755 kg)	13
10' (305 cm)	6" (15.2 cm)	127" (323 cm)	88" (224 cm)	2310 lbs. (1048 kg)	21
10' (305 cm)	8" (20.3 cm)	127" (323 cm)	88" (224 cm)	1950 lbs. (885 kg)	16



3311 Yates Avenue, Gilman, IA 50106  
641-498-2063 • Fax 641-498-2540 • [www.burchlandmfg.com](http://www.burchlandmfg.com)